

Centre for Research & Technology Hellas
Chemical Process & Energy Resources Institute



CPERI

Chemical
Process and
Energy
Resources
Institute

Advanced biofuels for transportation

Dr. Kostis Atsonios
Senior Research Scientist

18 April 2024





- ▶ Transport is responsible for about 25% of the EU's total CO₂ emissions
- ▶ The EU aims to reduce by 90% the greenhouse gas emissions from transport by 2050, compared with 1990
- ▶ Biofuels are crucial for reducing emissions in the transport sector
- ▶ Major role on the so-called “hard-to-abate sectors” aviation and maritime decarbonization

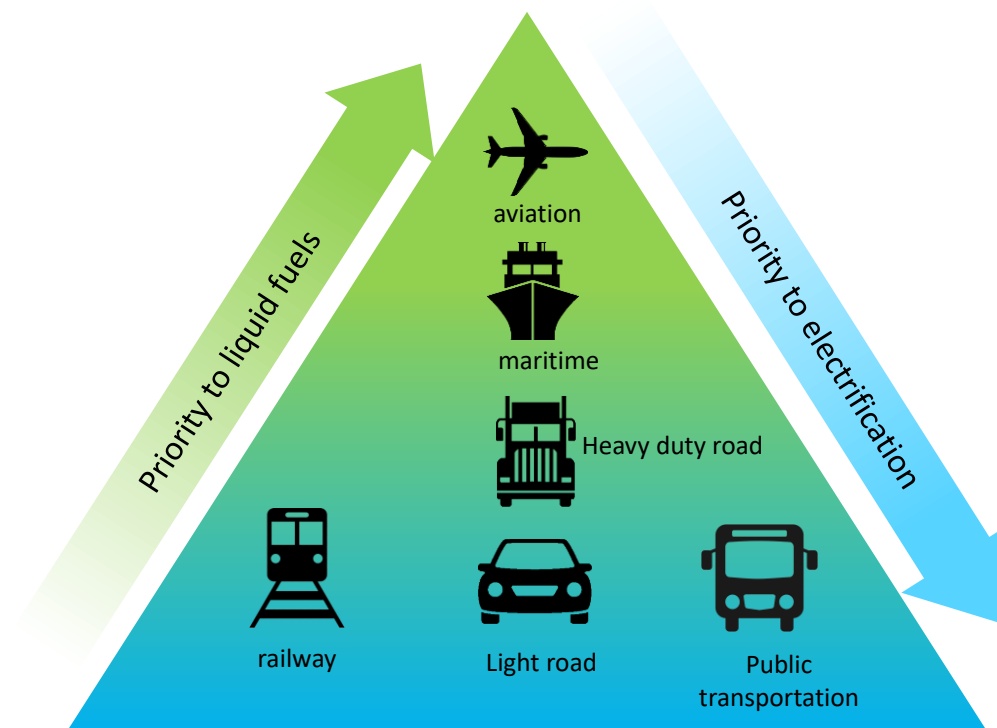
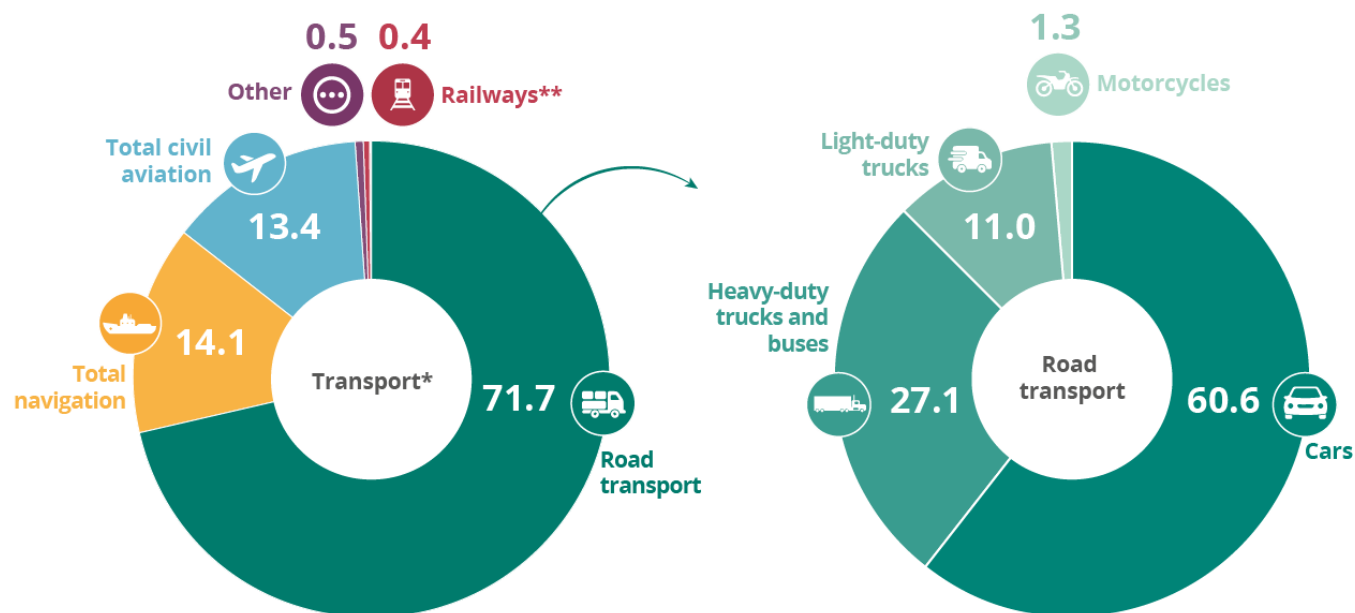

Advanced biofuels production pathways

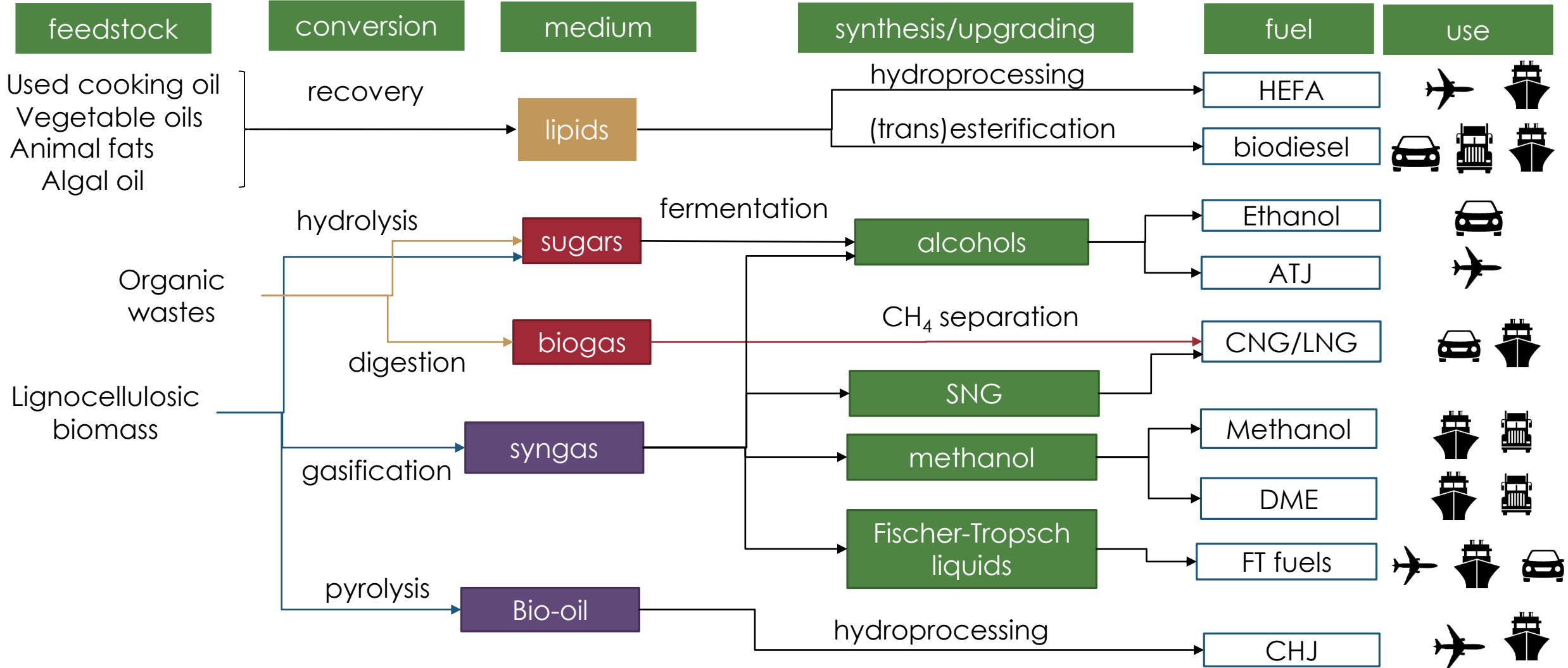

Renewable synthetic fuels production pathways

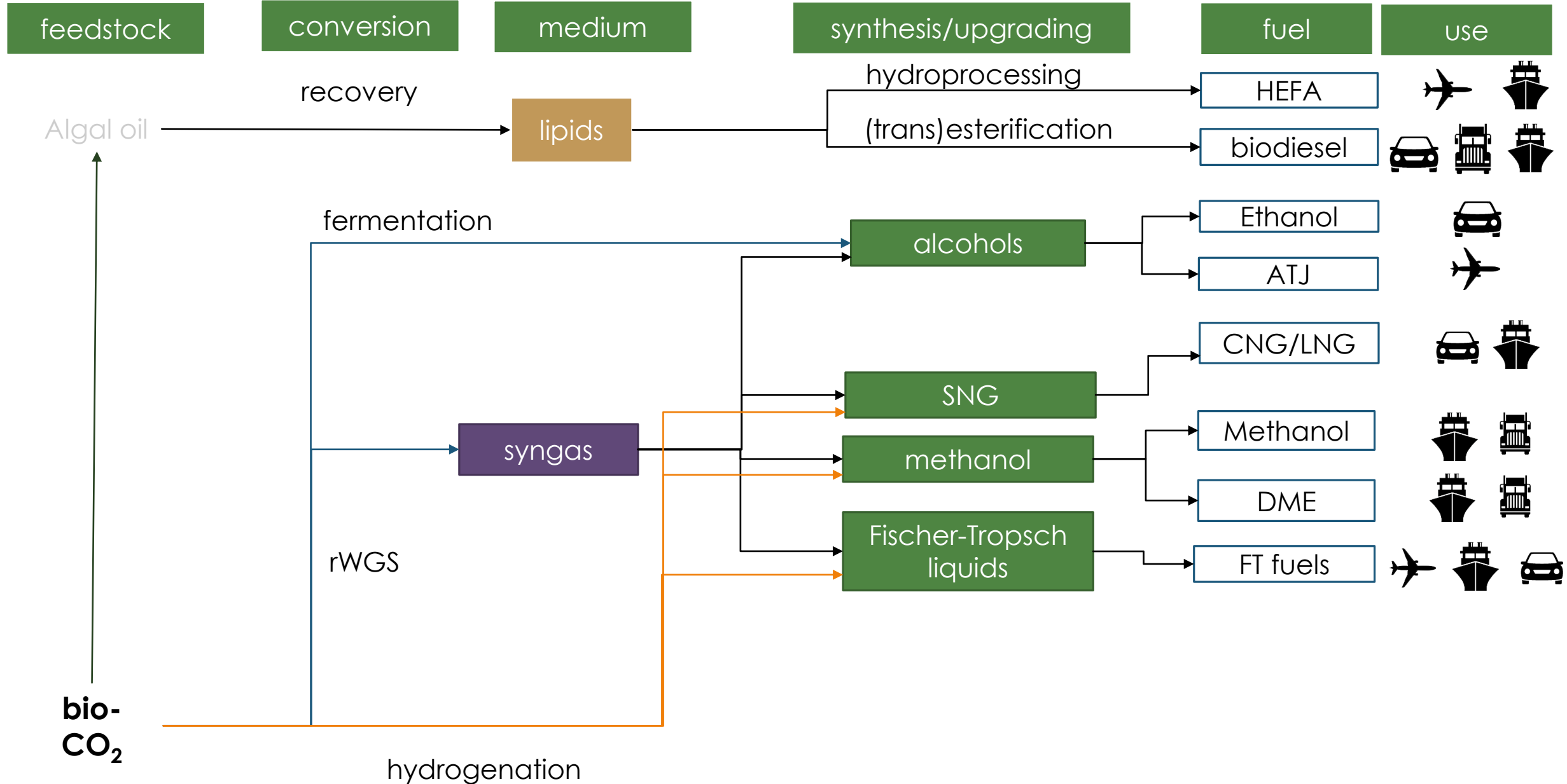

Advanced biofuels and renewable synthetic fuels production pathways

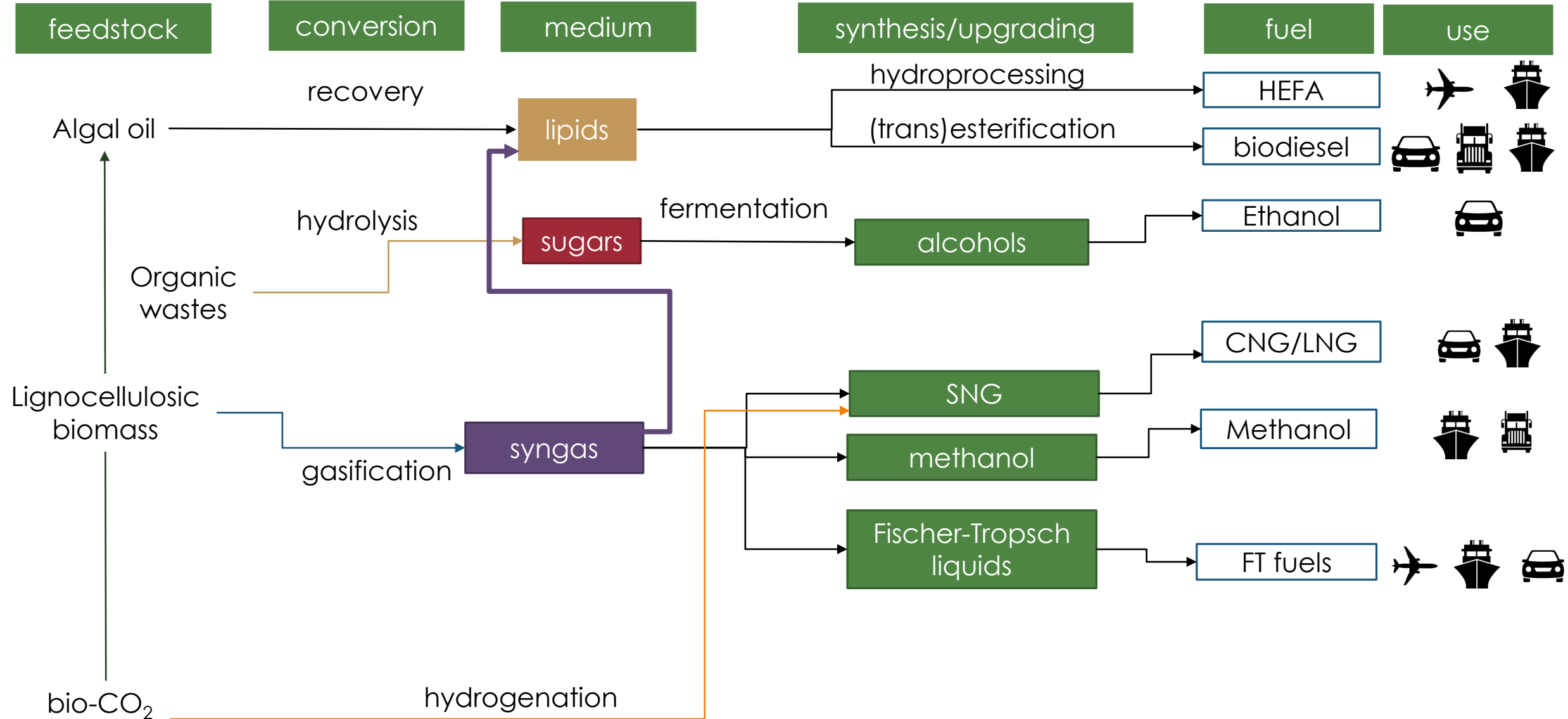

Drop-in aviation and marine biofuels through a combined thermochemical – biochemical pathway: the **BioSFerA** project



Development and validation of a novel biorefinery concept based on 2-step biological gas-to-liquid process using syngas from Dual Fluidised Bed Gasifier for the production of hydrotreated triacylglycerides (HTAGs)

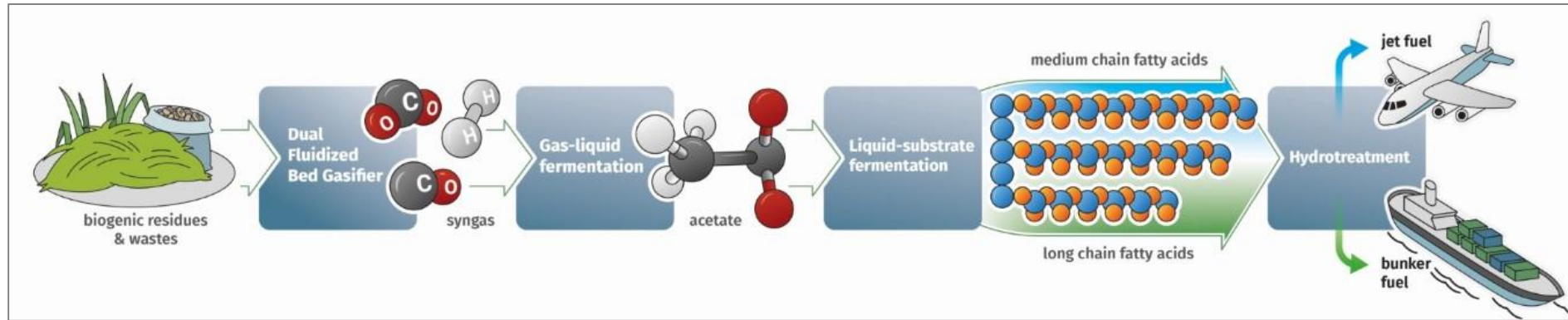

⌚ April 2020 – March 2024

💰 € 4,998,654

🌐 www.biosfera-project.eu

🇪🇺 Horizon 2020 (884208)



Fuel flexibility, minimal the gas cleaning requirements, low opex, enhanced yields of the target biofuels

CERTH role: **coordination**, feedstock characterization, process simulations, CFD analysis, lipids hydrotreating tests at lab/pilot scale, techno-economic evaluation, LCA





Drop-in aviation and marine biofuels through a combined thermochemical – biochemical pathway: the **BioSFerA** project

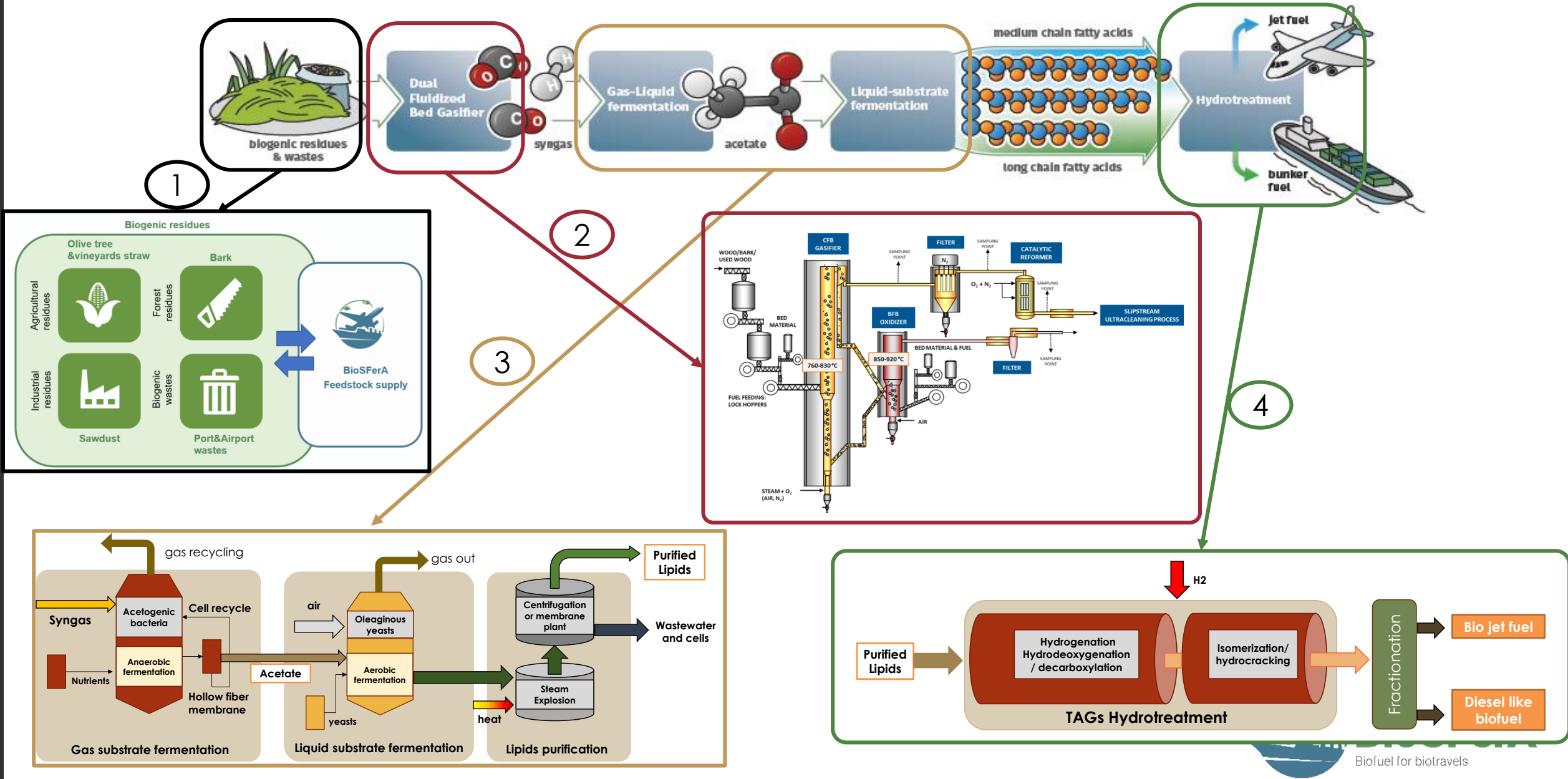

Drop-in aviation and marine biofuels through a combined thermochemical – biochemical pathway: the **BioSFerA** project



TRL3

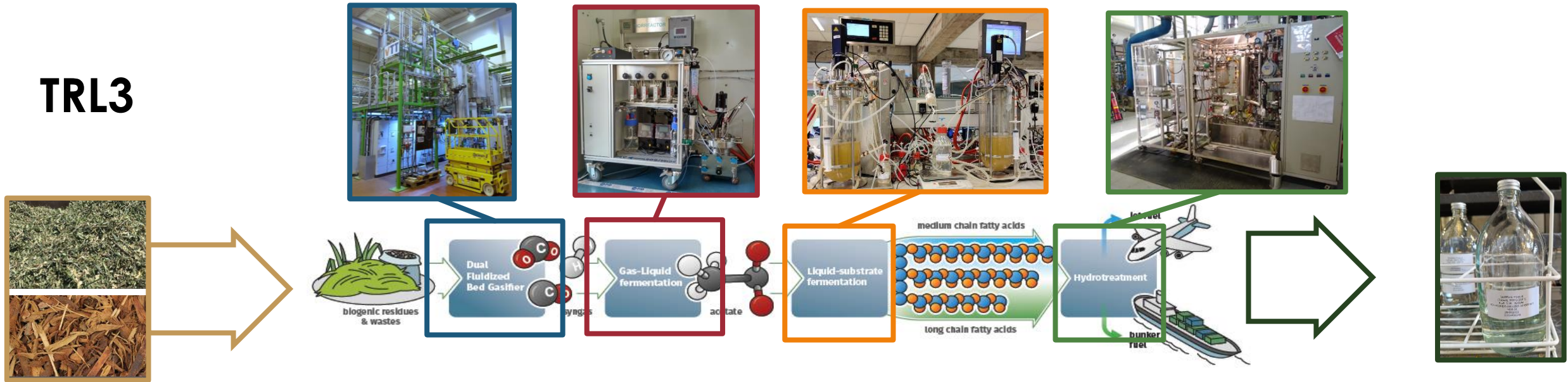

Drop-in aviation and marine biofuels through a combined thermochemical – biochemical pathway: the **BioSFerA** project

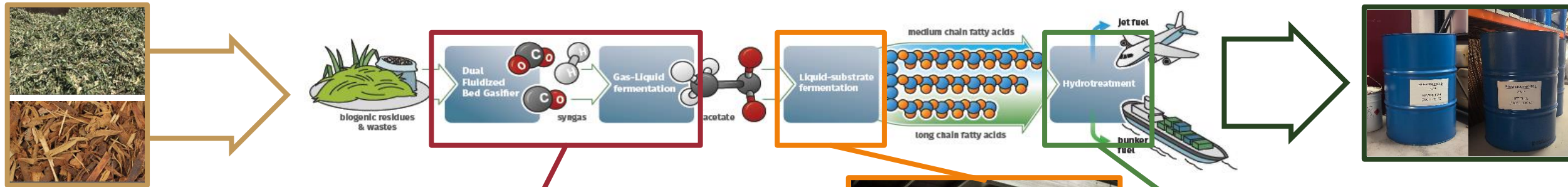

TRL5



Drop-in aviation and marine biofuels through a combined thermochemical – biochemical pathway: the **BioSFerA** project



Key results & conclusions

- Successful piloting of the Gasification and Gas fermentation plants with acetate production rate 0.77 g/L/h
- Less syngas cleaning steps than thermocatalytic pathways (FT) are required
- Lipid production using three substrates (acetate, glucose, glycerol) achieving a rate up to 0.261 g/L/h
- No intermediate acetate purification step prior liquid fermentation is required
- 35.6% energy efficiency, 25.4% total C utilization
- Baseline MJSP: 1.83 €/L
- GHG emission savings: 48% to 86% compared to conventional fossil fuels
- Most environmental case: GHG emissions at 15.5 g CO₂_{eq}/MJ_{fuel}

Added value & legacy

- Introduction of a new sustainable feedstock for HEFA plants
- Bio-syngas fermentation runs at pilot level for first time ever
- Drop-in biofuels from microbial oil hydrotreatment for first time ever
- New strains constructions for advanced lipids production
- Expanding the portfolio for producing microbial oil from various sources and substrates



Full chain 2nd generation biofuel production based on chemical looping gasification: the **CLARA** project



Development of a concept for CLG of biogenic residues and demonstration the full process chain at a 1MW_{th} unit

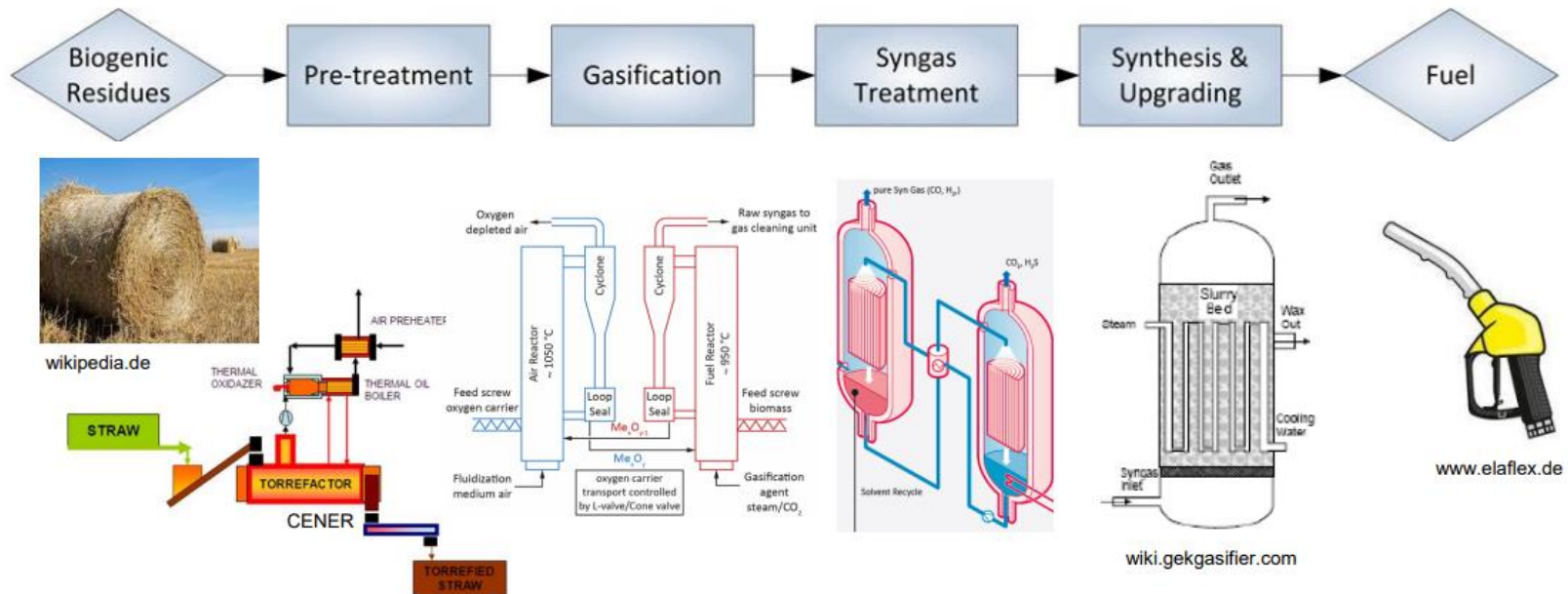

Biogenic residues

Torrefaction, leaching, pelletization

Chemical looping gasification

Cost efficient acid gas removal

Fischer-Tropsch synthesis, Hydrocracking

Liquid fuel (Gasoline, diesel)



Cost competitive and environmentally compatible fuels for road transport

CERTH role: steady and dynamic process simulations, waxes hydrocracking tests



Project coordinator

EST TECHNISCHE UNIVERSITÄT DARMSTADT

TU WIEN

ORLEN UniCRE

CSIC

JÜLICH Forschungszentrum

Ulster University

UNIVERSITÀ DEGLI STUDI DE L'AQUILA

repotec renewable power technologies

CENER RWE

CHALMERS UNIVERSITY OF TECHNOLOGY

AB TORKAPPARATER THERMAL PROCESSING EQUIPMENT

⌚ Nov 2018 – March 2023

💰 € 4,993,805

🌐 www.clara-h2020.eu

🤝 Horizon 2020 (817841)



Full chain 2nd generation biofuel production based on chemical looping gasification: the CLARA project

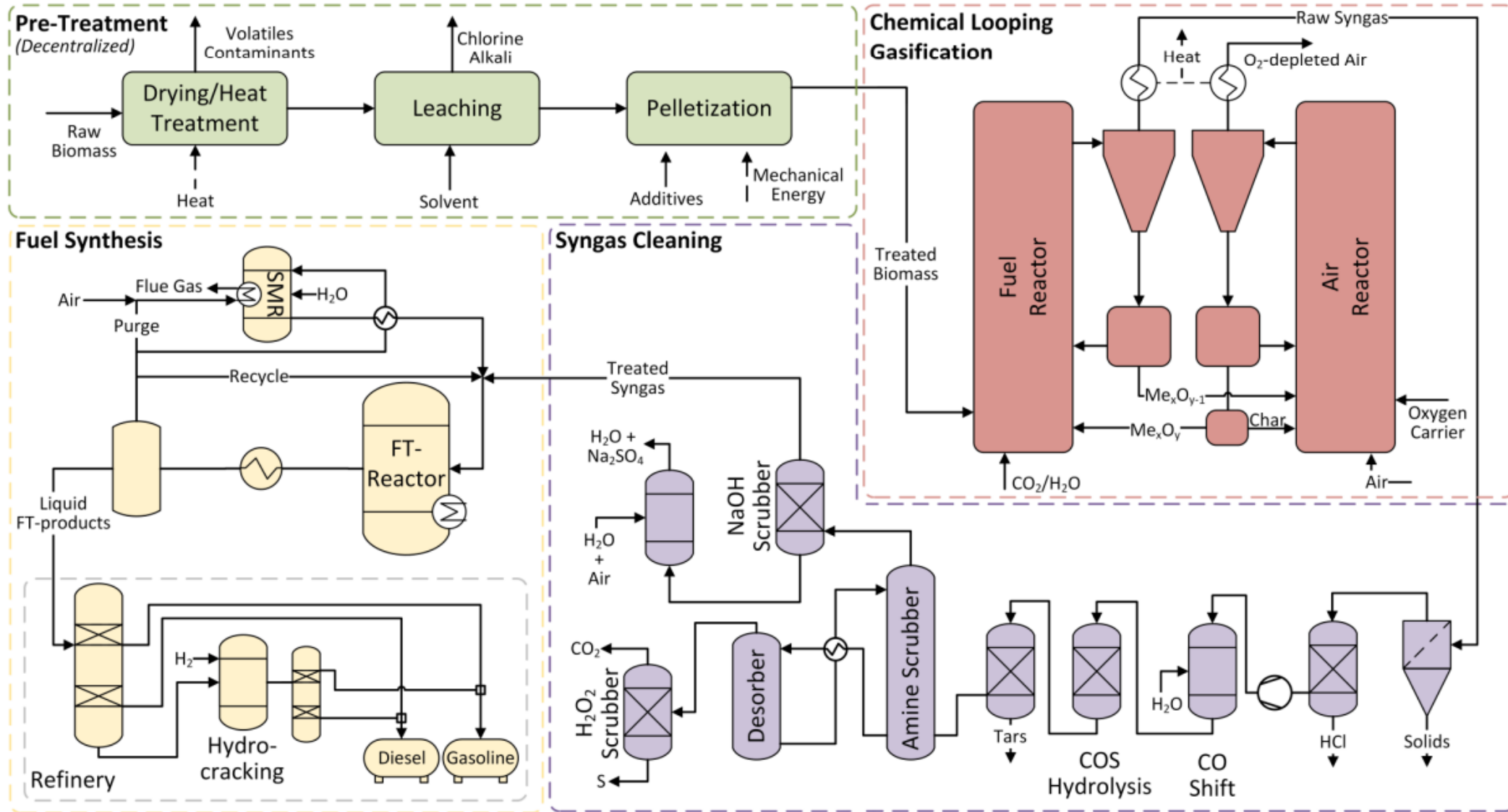

Full chain 2nd generation biofuel production based on chemical looping gasification: the **CLARA** project

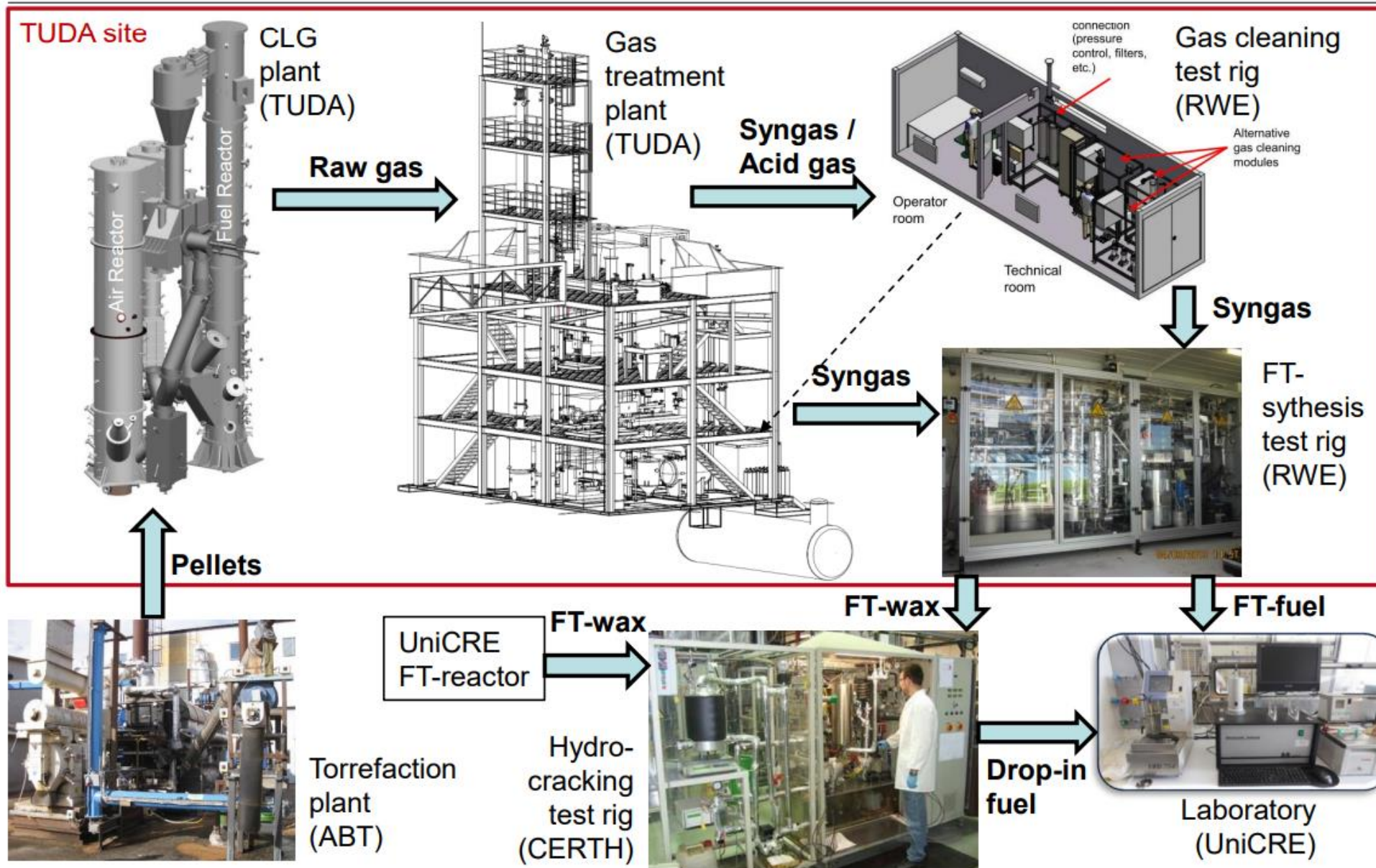

Flexible Production of Synthetic Natural Gas and Biochar for Biomass and Waste Feedstocks: the **FlexSNG** project



to develop and validate (TRL5) a flexible and cost-effective gasification-based process for the production of **pipeline-quality biomethane**, **high-value biochar** and **renewable heat** from a wide variety of low-quality biomass residues and biogenic waste feedstocks

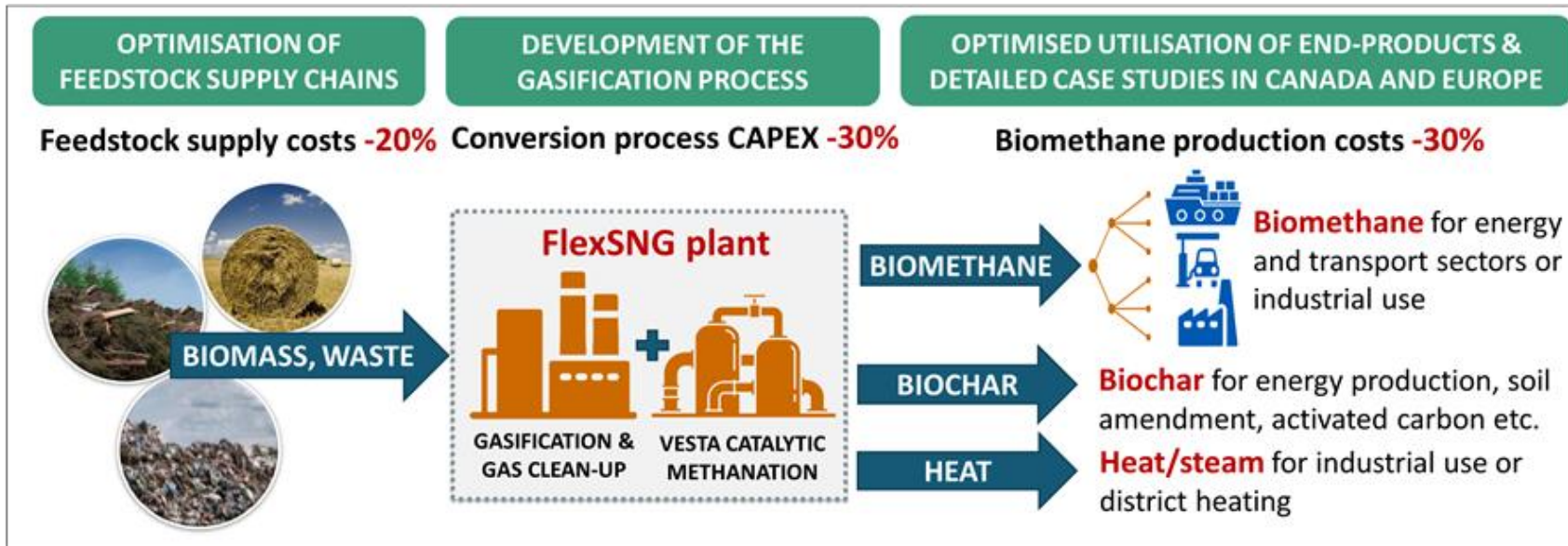

Switch between operation modes to adapt to market signals and feedstock availability and price



CERTH role: design and model development of the FlexSNG process concepts, CFD, South Europe case studies analysis, LCA analysis

VTT Project coordinator

CERTH CENTRE FOR RESEARCH & TECHNOLOGY HELLAS

skogforsk

DTU

CREATIVE OPTIMIZATION SWEDEN AB

EIFER

wood.JM Johnson Matthey Inspiring science, enhancing life

Sumitomo SHI FW

UNIVERSITÉ LAVAL

POLYTECHNIQUE MONTRÉAL

eta florence renewable energies

⌚ June 2021 – May 2024

€ € 4 230 810

🌐 www.flexsng.eu

👤 Horizon 2020 (101022432)



FlexSNG

Flexible Production of Synthetic Natural Gas and Biochar for Biomass and Waste Feedstocks: the **FlexSNG** project

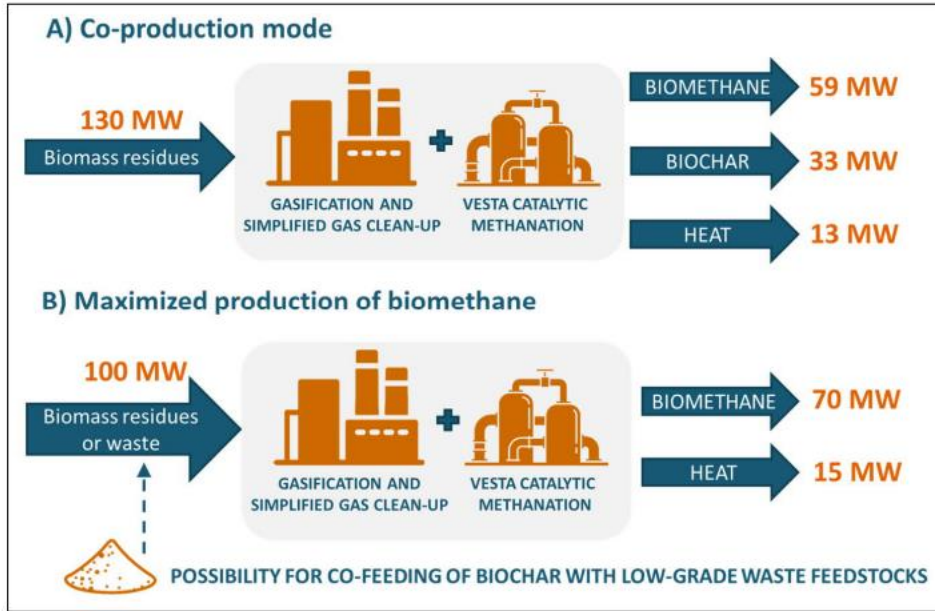

“One plant, two modes”

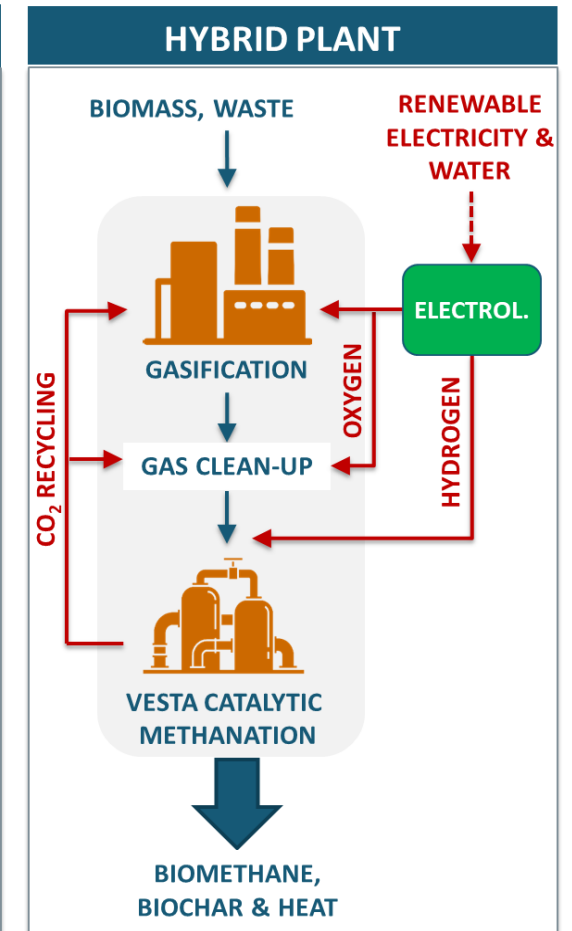
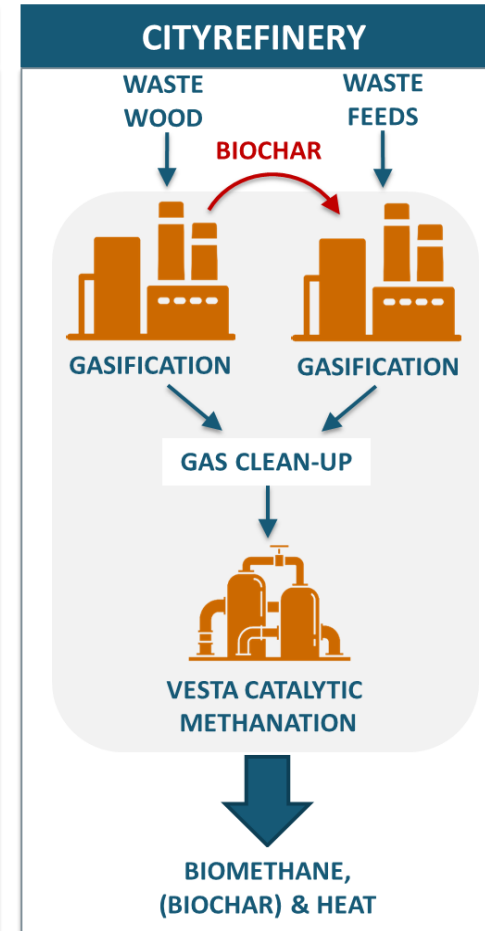
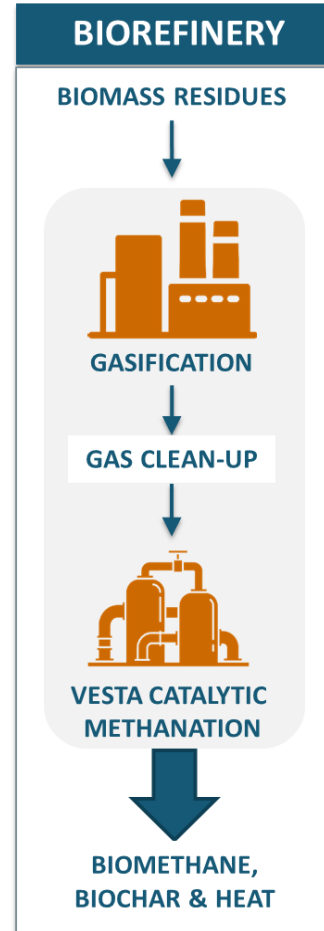



State of the art bio-SNG production technology

- Based on steam/oxygen-blown circulating fluidised-bed (CFB) gasification

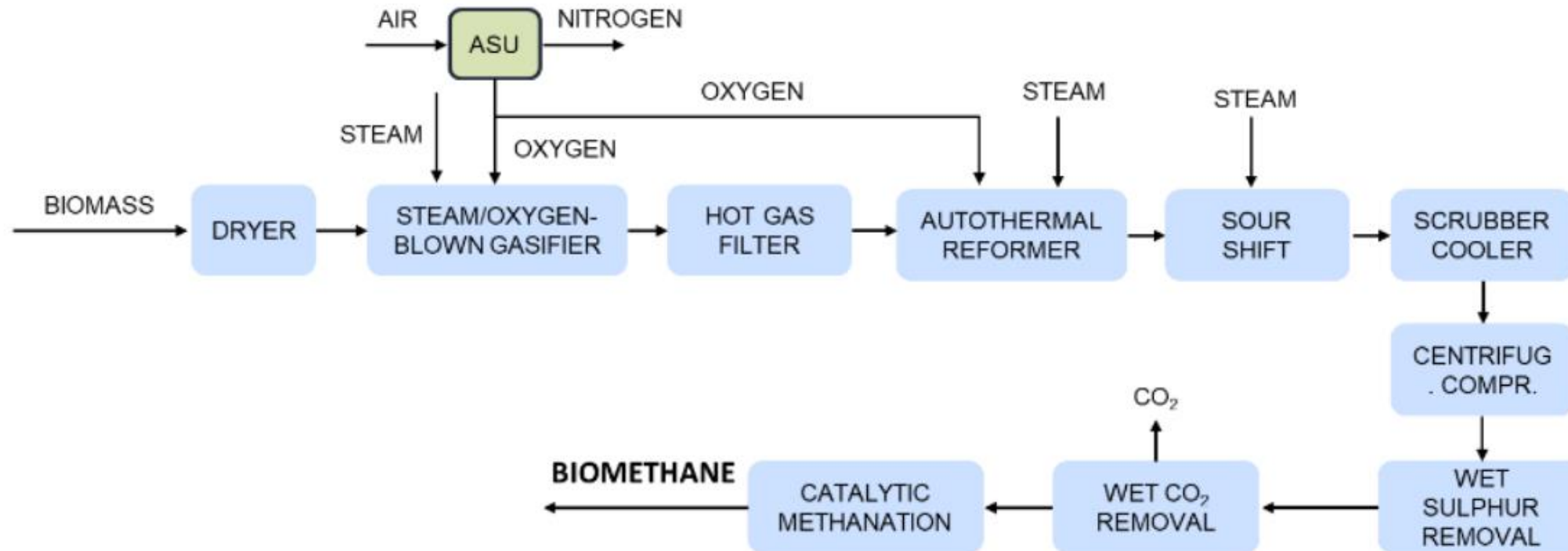

Flexible Production of Synthetic Natural Gas and Biochar for Biomass and Waste Feedstocks: the **FlexSNG** project



The FlexSNG process

MINIMIZE OXYGEN DEMAND AND NEW INNOVATIVE OTM TECHNOLOGY: -10% CapEx

ELIMINATE WGS SHIFT STEP: -5% CapEx

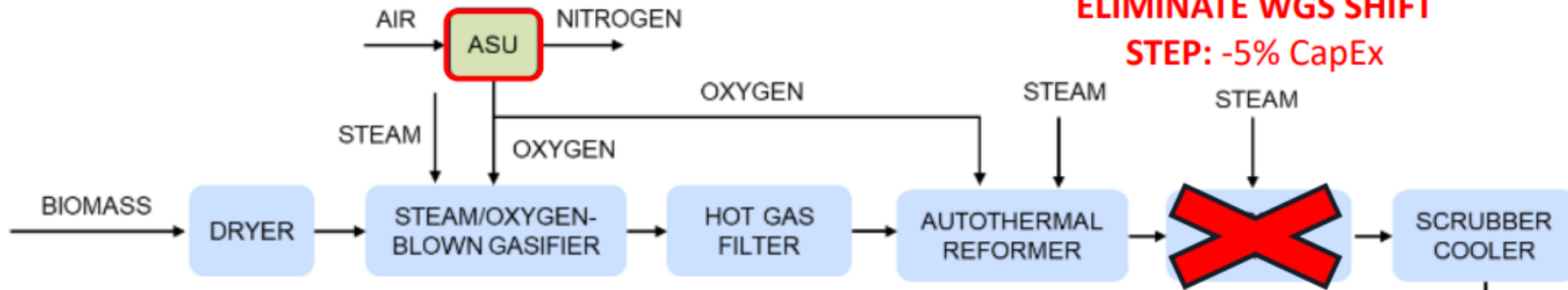

COST SAVINGS VS. STATE-OF-ART	
Oxygen supply	-10 %
WGS step	-5 %
Sulphur removal	-5 %
Methanation	-10 %
TOTAL:	-30%

SIMPLIFY METHANATION: -10% CapEx

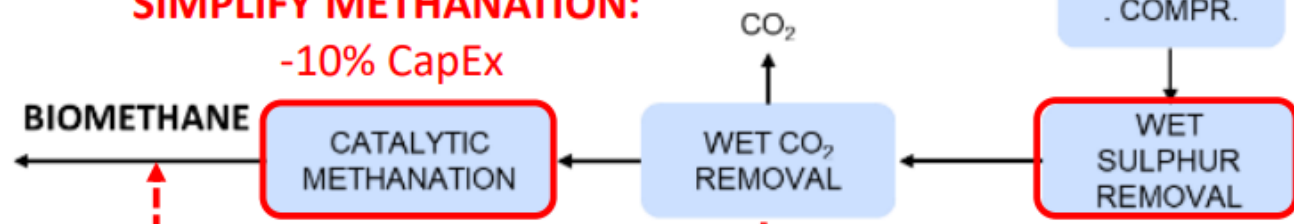

REPLACE WITH DRY SULPHUR REMOVAL: -5% CapEx



Accelerating the sustainable production of advanced biofuels and RFNBOs - from feedstock to end-use: the **FUELPHORIA** project



Demonstrate robust and cost-effective technological solutions for the production of advanced biofuels & RFNBOs from sustainable feedstocks and renewable energy

Project Dimensions

Sustainable Feedstock

Including **residues and wastes, CO₂**, and renewable **hydrogen**.

Competitive state-of-the-art technologies

Test and evaluate state-of-the-art pathways which are **biochemical, thermochemical, biological, chemical, photobiological, electrochemical** or a combination of them.

High quality-end products

Including fuels that meet quality specifications as defined for use in the **transport** sector and in the **power** production sector.

Foster Exploitation

of advanced biofuels and RFNBOs through:

- identifying **barriers in value chains** at EU level and in Africa
- new **business and marketing concepts** in Europe and Africa
- through **policy recommendations** at EU level



 Oct 2023 – Sept 2027

 € 9,812,005.39

 <https://fuelphoria.eu/>

 Horizon Europe (101118286)



CERTH role: Project coordination, DEMOs process modeling & upscaling, Assistance and supervision on pilot operation, Technical evaluation of DEMOs results

FUELPHORIA



Demos overview

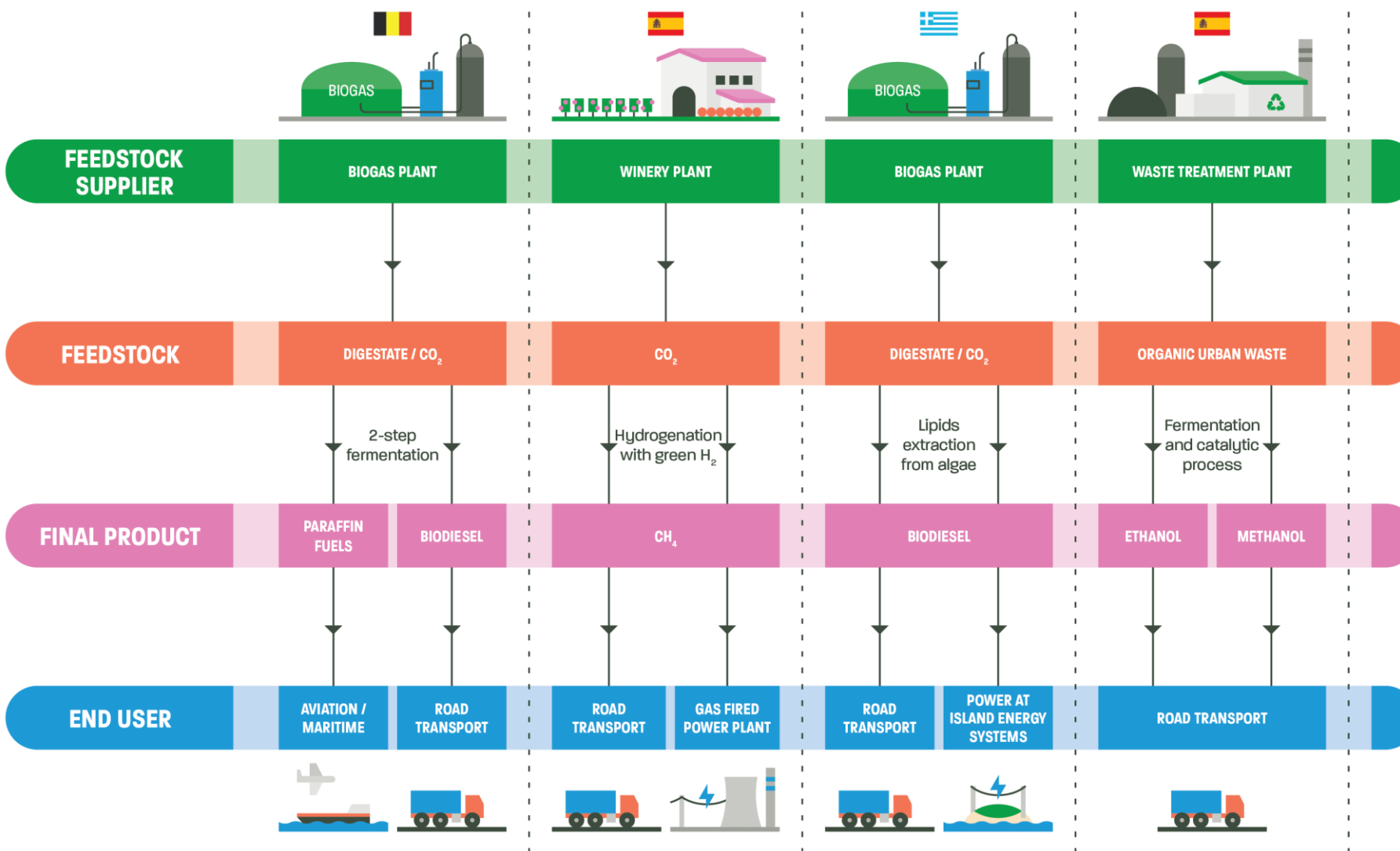

Conclusions



- ▶ New technologies with upgraded specifications in terms of performance and feedstock flexibility strengthen the competitive advantage of thermochemical biomass utilization processes
- ▶ Biomass can play an important role in meeting the demands for sustainable transport. Advanced technologies offer the possibility of utilizing solid fuels and biogenic waste
- ▶ Biogenic CO₂ is a promising carbon source for the production of advanced renewable fuels with green H₂
- ▶ High expectations for biofuels to establish a leading role in transport and especially in aviation is the initiative ReFuelEU Aviation
- ▶ CERTH is actively involved in EU level research efforts to develop these technologies for the production of advanced biofuels for transport

Thank you!



This project has received funding from the European Union's Horizon 2020 research and innovation programme under grant agreement No 884208



This project has received funding from the European Union's Horizon 2020 research and innovation programme under grant agreement No 817841.



FlexSNG

This project has received funding from the European Union's Horizon 2020 Research and Innovation Programme under Grant Agreement No. 101022432 and the Government of Canada's New Frontiers in Research Fund (NFRF) and the Fonds de recherche du Québec (FRQ).



This project has received funding from the European Union's Horizon Europe research and innovation programme under grant agreement No 101118286

